



ORIFICE PLATES & ORIFICE FLANGE ASSEMBLIES



**EUREKA
INDUSTRIAL
EQUIPMENTS
PVT. LTD.**

REGD. & SALES OFFICE : 17-20, 1st Floor, Royal Chambers, Paud Road, Pune 411 038, Maharashtra, India.
Tel: 0091-20-25443079, 25451314 Fax: 0091-20-25441323 Email: sales@eurekaflow.com / eurekaflowmail@vsnl.net

FACTORY : 501, 'J' Block, M.I.D.C. , Pimpri, Pune - 411 018. Tel: 0091-20-27460585, 306817 31 to 55
Fax: 0091-20-27460586 Email: eurekaflowmail@vsnl.net

MUMBAI OFFICE : Office No.116, Growmore Tower, 1st Floor, Plot No.5, Sector No.2, Kharghar, Navi Mumbai - 410 210
Mobile: 9322598274

AUTHO. SERVICE CENTRE : Eureka Hightech, 281/1, Plot No.38, Kasar Amboli, Tal. Mulshi, Pune-412 108 Tel: 020-22922170

Website: www.eurekaflow.com

Integral Orifice Assembly

Integral Flow Orifice Assembly is used for the small bore pipe sizes of 2" & below. However due to process Temperature limits of the Transmitter , this assembly cannot be used for process Temperatures above 120°C (248°F).

The assembly consists of an Orifice Plate between two integral blocks having corner taps. Generally meter run pipe is recommended with upstream length of 750mm and downstream length of 250mm.

The pipes are welded to the blocks with end flanges. The complete Flow Measuring System consists of Integral Orifice Assembly, Manifold and DP Transmitter. At Eureka we have in house Calibration Facility for the calibration of Integral Orifice Assemblies that we manufacture. Calibration can be offered upon Customer's request. These Integral Assemblies can be offered in CS, SS316, SS304 and other materials on specific request.

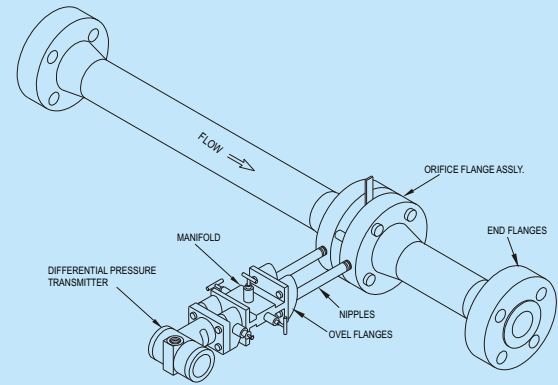

ORIFICE FLANGE ASSEMBLY WITH PIPE RUN, MANIFOLD, DP TRANSMITTER, & END FLANGES

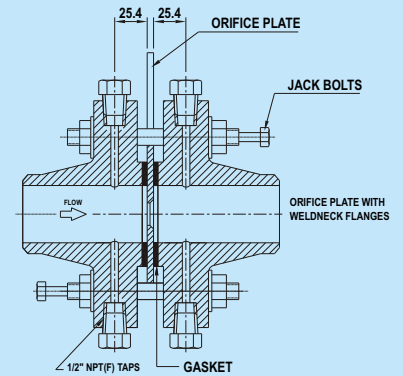

ORIFICE PLATE WITH WELDNECK FLANGES

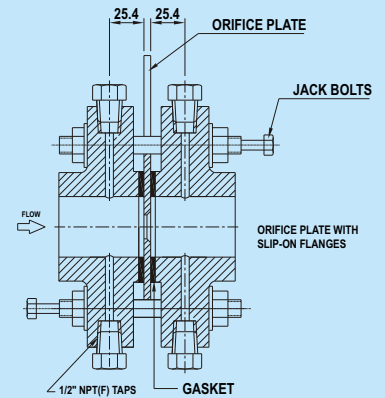

ORIFICE PLATE WITH SLIP-ON FLANGES

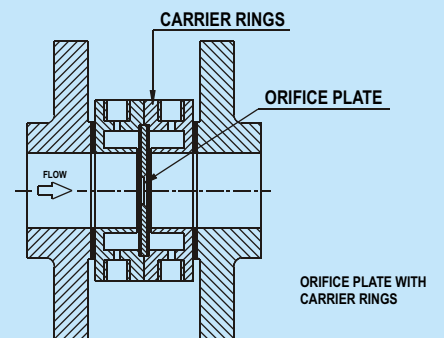

ORIFICE PLATE WITH CARRIER RINGS

Orifice Flange Assemblies



Orifice Plate With Weld Neck Flange Union

The Weld Neck Flange is normally referred to as "high Hub" flange. It is designed to transfer stresses to the pipe, thereby reducing high stress concentrations at the base of the flange. The pressure tapings are provided through the flange which are at a distance of 1" from the face of the plate (shown in the drawing attached).

Orifice Plate With Slip On Flange Union

The Slip On Flange has a "low hub" because the pipe slips into the flange prior to welding. It is welded both from inside and out to provide sufficient strength and prevent leakage. The slip on flanges are bored slightly larger than the OD of the matching pipe.

Orifice Plate With Carrier Ring

The construction is similar to the above except Carrier Rings provide a low cost solution (corner tapping). Carrier ring machined from single block is also offered in place of male-female carrier, wafer type mounting is used for carrier rings.

Orifice Plate Assemblies with RTJ Holder

Description

The Plate Holder Assembly is a combination of plate holder and an Orifice Plate designed for Ring Tongue Joint (RTJ) Flanges. The plate holder has a function of holding the Orifice Plate and also functions as a gasket to prevent leakage of the process fluid. The plate holder has an oval or octagonal ring for mounting between ring type joint flanges. This metallic sealing system is useful for a fluid of high temperature and high pressure. The pressure tapping system normally is of the flange tap type.

Orifice Plate is screwed to the plate holder. Generally the plate holder is of soft Iron material. The Orifice Plate is available in standard material such as SS316, SS304, SS316L, Monel, Hastelloy-C, etc. Other materials are available on request.

Orifice Plates

Orifice Plates are most commonly used primary elements for flow measurement in pipelines based on the principle of measurement of 'Differential Pressure' created when an obstruction is placed in the fluid flow, due to increase in fluid velocity.

Orifice Plates cover a wide range of applications of fluid and operating conditions. They give an acceptable level of uncertainties at lowest cost and long life without regular maintenance.

We have fully equipped integrated designing, manufacturing and testing facilities which are amongst the best in the Country. Over the years we have manufactured and supplied Orifice Plate Assemblies to many prestigious projects in the Domestic as well as International market.

The Square Edged Concentric type of Orifice Plate is most commonly used for flow measurement. This has got features such as simple structure, high accuracy, and ease of installation & replacement. The Orifice Plates are correctly finished to the dimensions, surface roughness, and flatness to the applicable standard. These plates are recommended for clean Liquids, Gases & Steam flow, when the Reynolds number range from 10000 to 10^7 .

We also manufacture Eccentric Orifice Plates, Segmental Orifice Plates, Quadrant Edge Orifice Plates, Conical Entrance Orifice Plates.

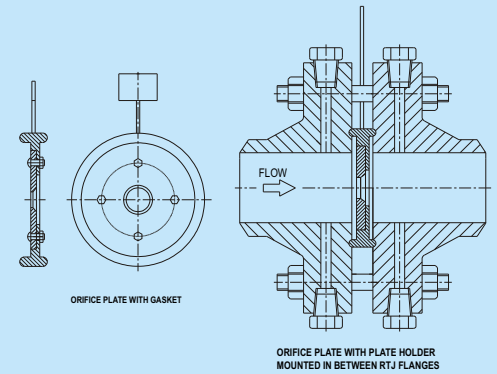
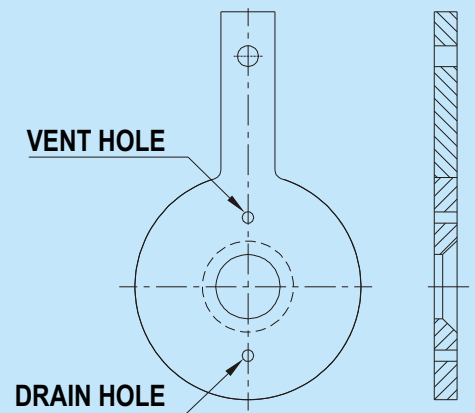

PLATE WITH PLATE HOLDER
MOUNTED IN BETWEEN RTJ FLANGES



SQUARE EDGED
CONCENTRIC ORIFICE PLATE



Restriction Orifice Plates

The Restriction Orifice Plates are used for reducing fluid pressure and are designed somewhat different from the Orifice Plates that are used for measuring flow rates. They are designed to slip between the piping flanges.

While single Restriction Orifices are often sufficient to meet the requirements, there are situations where limitations arise due to process conditions making the single Restriction Orifices unacceptable. In such situations, use of Multiple Restriction in series is a better solution.

The foremost consideration in using Multiple Restriction is the pressure drop. Higher pressure drop implies higher velocities resulting in vibration and noise problems. Hence instead of a Single Restriction Orifice Plate, Multiple Plates are used.

The other consideration, particularly for gas flow is that if the process condition indicates that critical flow will occur with the use of single restriction plate, care should be exercised to avoid operating well beyond the critical pressure drop.

Construction of Multistage Orifice Assembly is as shown in the adjoining sketch. End connection is either suitable for butt welding or with end flanges.

SR.NO.	PART NAME
1	PROCESS FLANGES WELDNECK
2	RESTRICTION ORIFICE PLATE
3	PIPES

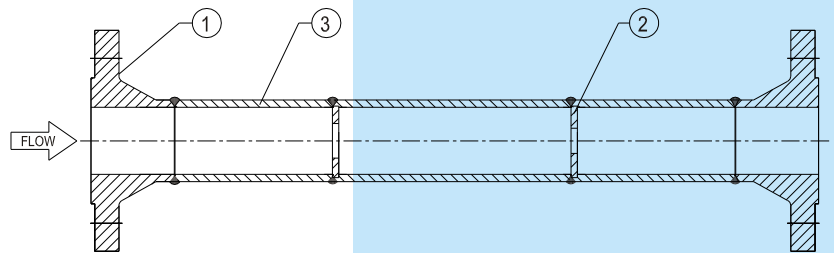

MULTIPLE RESTRICTION ORIFICE ASSEMBLY

Specifications

Design	: Conforms to ISA RP 3.2 , DIN 1952 , BS 1042, ISO 5167, ASME MFC - 3M
Types	: Square edge concentric, Quadrant edged, Conical entrance, Eccentric, Segmental.
Plate Material	: AISI SS 316 as standard. SS304, SS316L, Hastelloy-C , Monel , PP, PVC , PTFE coated , etc. can be given on request.
Orifice Bore	: In accordance with ISO 5167, BS 1042, ASME MFC 3M, R.W.Miller, L.K.Spink, AGA-3
Tag Plate	: In the same material as Plate & is welded to Orifice Plate. Tag plate integral to the Orifice Plate (i.e. without welding) can also be offered as a special case.
Vent / Drain	: Vent or Drain holes are provided as per customer's requirement.
Flange Type	: Weld neck, Slip on, Threaded, Socket welded with RF or RTJ facing Orifice flanges are in accordance with ASME B16.36 with minimum flange rating of 300# or male - female flanges in accordance with B16.5.
Flange Material	: ASTM A 105 as standard, ASTM A182 F11, ASME ASTM A 350, ASTM A182 F316, ASTM A182 F304, ASTM A 182 F 316L, ASTM A 182 F 304L, FRVE etc.
Pressure Tappings	: Corner tappings are recommended for sizes upto 1 1/2"; Flange taps from 2" to 16" ; D - D/2 taps for higher sizes.
Gasket	: SS spiral wound + Grafoil, SS spiral wound + PTFE are normally supplied as per process requirement. Other materials available on request. For RTJ flanges , the plate is fixed on the plate holder. The plate holder is in Soft Iron material & acts as a gasket .
Studs / Nuts	: ASTM A193, Gr. B7/A-194 Gr.2H as standard, Other material on request.
Jack Screw	: Carbon Steel (CI 038 heat treated)

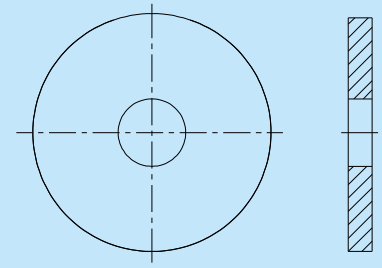

RESTRICTION ORIFICE PLATE

Data required for sizing :

- Name of Fluid
- Sp. Gr. Of Fluid at Operating Conditions
- Viscosity of Fluid at Operating Conditions
- Operating Pressure & Operating Temperature
- Measuring Range
- Material of Construction desired.